

Bicycle Rails

Most hitching rails are supplied complete with 200mm x 100mm rectangular base plates, allowing for installation by one of 3 methods:

- Bolt down using masonry anchors
- Fixed insitu (cast in)
- Connection to base rails

The main advantage of using the base rail system is that it eliminates the need for concrete footings

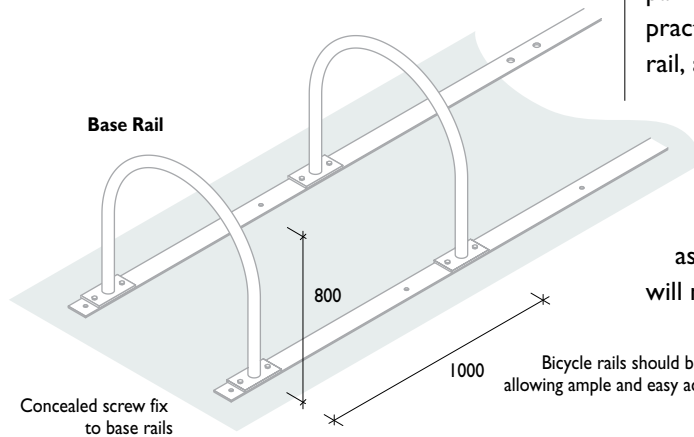
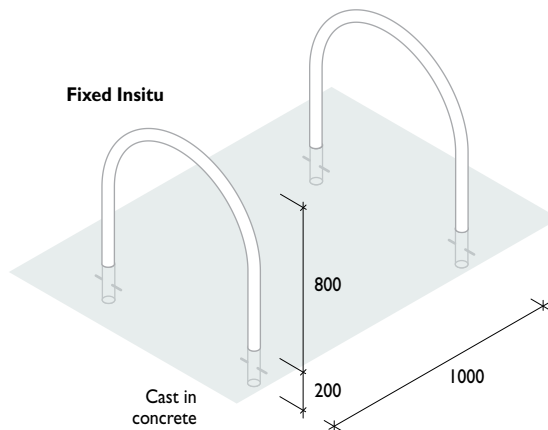
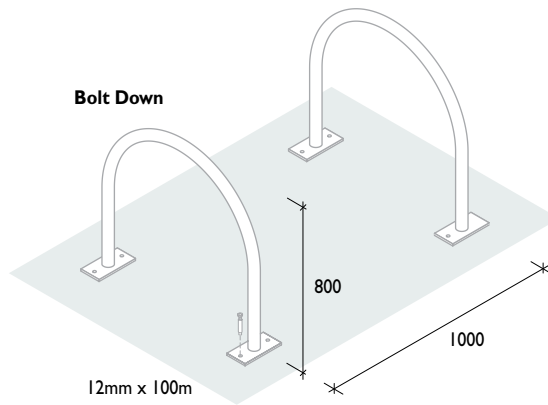

Bicycle rails should be installed at 1200 centres allowing ample and easy access for cyclists.



and substantially reduces installation costs. It also allows the unit to be relocated with minimum effort and cost. Security is maintained by the overall weight of the combined system.

While bicycle hitching rails potentially provide parking for two bicycles (one either side), in practice they usually only achieve one bicycle per rail, as cyclists are often reluctant to secure their bicycle if another is already tethered to the rail.

All bicycle frames that allow a bicycle's frame and both wheels to be secured, as well as being spaced at 1000mm apart, will meet the requirements of AS2890.3.